

SL19 / SL26 / SL36 / SL50

Coolbeam Spotlights 600W

Excellent light output, superb distribution and the smoothest soft edge while maintaining beam size. Sharp gobo, edge and shutter focus.

Very compact and narrow with the smallest dimensions in their category. Easy to use and maintain with many features for increased safety.



Features

- Precision optical system with high light output
- High efficiency dichroic glass reflector and coated aspheric computer-designed lenses
- Coolbeam operation for extended gobo, shutter and gel life
- Optimised for energy efficient, high performance GKV 600W lamps; GLB long life lamps also available
- Consumes significantly less energy while providing more light than most conventional 1000W/1200W spotlights
- Fast and easy lamp centring with positive screw driver lock so that it won't move in transit
- Fast positive peak/flat adjustment via lead screw drive mechanism for smooth, tool-free field settings
- Bayonet action lamp changing system for simple lamp changes without affecting field setting
- Compact and lightweight, allowing closer hanging in tighter spaces
- Smooth 360° body rotation for quick and easy gobo and shutter positioning
- Shutters in three planes for triangular shutter cut
- Highly versatile rigging by combining 360° rotation with two balance positions for yoke
- Large rear handle for easy positioning
- Quick and easy access for reflector and lens cleaning
- Common lamp house with easily interchangeable tubes
- Wide gate will fit 2 gobo holders, including glass gobo holder, drop-in iris or rotating goboholder
- Safety bond attachment point for the luminaire and accessories
- CE marking

SPECIFICATION SUBMITTAL

CONSULTANT <input type="text"/>	PROJECT NAME: <input type="text"/>	MODEL NUMBER QUANTITY: <input type="text"/> <input type="text"/> <input type="text"/> <input type="text"/> <input type="text"/> <input type="text"/> <input type="text"/> <input type="text"/>
DATE: <input type="text"/>	PROJECT NUMBER: <input type="text"/>	APPROVED BY: <input type="text"/>

Photometric data

Typical performance based on: 600W GKV 230/240V lamp

SL19

Distance (m)	5	10	15	20	25
Beam Ø (m)	1.7	3.3	5.0	6.7	8.4
Illum (lux)	5080	1270	564	318	203

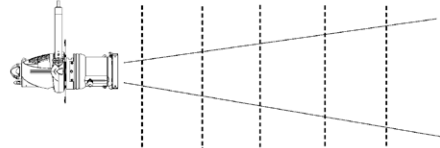

Beam candle power (cd) 127,000

SL26

Distance (m)	5	10	15	20	25
Beam Ø (m)	2.3	4.6	6.9	9.2	11.5
Illum (lux)	4280	1070	476	268	171

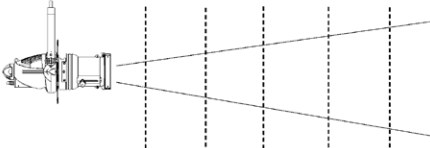

Beam candle power (cd) 107,000

SL36

Distance (m)	5	10	15	20	25
Beam Ø (m)	3.2	6.5	9.7	13.0	16.2
Illum (lux)	2400	600	267	150	96

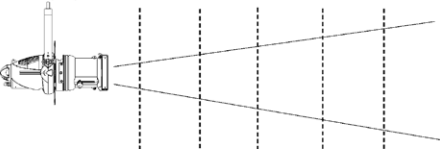

Beam candle power (cd) 60,000

SL50

Distance (m)	5	10	15	20	25
Beam Ø (m)	4.7	9.3	14.0	18.7	23.3
Illum (lux)	1800	450	200	113	72

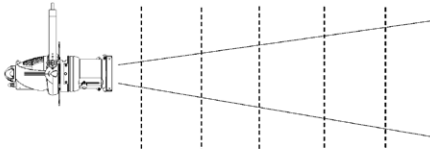

Beam candle power (cd) 45,000

Performance at any distance: divide beam candle power by distance²

For beam diameter at any distance:

- 19° multiply 0.32 x distance
- 26° multiply 0.46 x distance
- 36° multiply 0.64 x distance
- 50° multiply 0.93 x distance

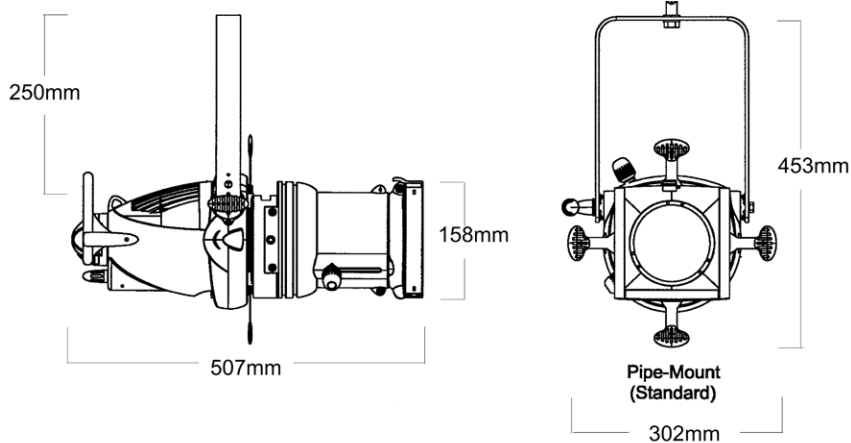

Weights and Dimensions

Weight	6.8kg
Packed weight	9.4kg
Packed volume	0.075m ³ / 605x350x350mm
Filter cut size	158mm x 158mm

Operational features

Focus adjustment: By moving the burner assembly using a simple screw drive mechanism.

Lamp Adjustment: Lamp centring by use of a screwdriver

Electrical & Mechanical data

Construction: Die cast aluminum housing with black epoxy powder coat. Stainless steel shutters.

Gate: Plated steel

Lenses: Crown glass coated aspheric lens

Lamp:

G9.5 base

GKV 400 hours 3200°K

GLB 1500 hours 3100°K

Supply voltage: 120-240V, 50/60 Hz

Standards compliance: CE marking

Max operating ambient temperature: 45°C

Ordering Information

Cat No Description

SL 19, 26, 36, 50 are supplied with 360° rotation mounting yoke, colour frame, and 1.0m of power cable.

11320 SL19, 230/240V, be

11330 SL26, 230/240V, be

11340 SL36, 230/240V, be

11350 SL50, 230/240V, be

For connector options please specify when ordering.

Optional Accessories

18045 Gobo holder size B

18049 Iris (24 leaf)

18114 Colour frame

18403 19° lens tube

18404 26° lens tube

18405 36° lens tube

18406 50° lens tube

18115 High hat

18143 Donut

Strand Lighting Europe Limited

Unit 2 Royce Road, Fleming Way
Crawley, West Sussex RH10 9JY
Tel: + 44 (0) 1293 554010
Fax: + 44 (0) 1293 554019

Strand Lighting Asia Limited

20/F Delta House,
3 On Yiu Street
Shatin, N.T. Hong Kong
Tel: +852 2757 3033
Fax: +852 2757 1767

Strand Lighting, Inc.

6603 Darin Way
Cypress, CA 90630
Tel: (714) 230-8200
Fax: (714) 899-0042

www.strandlighting.com

© Philips Group 2008
All rights reserved.

The Company reserves the right to make any variation in design or construction to the equipment described. E&OE